

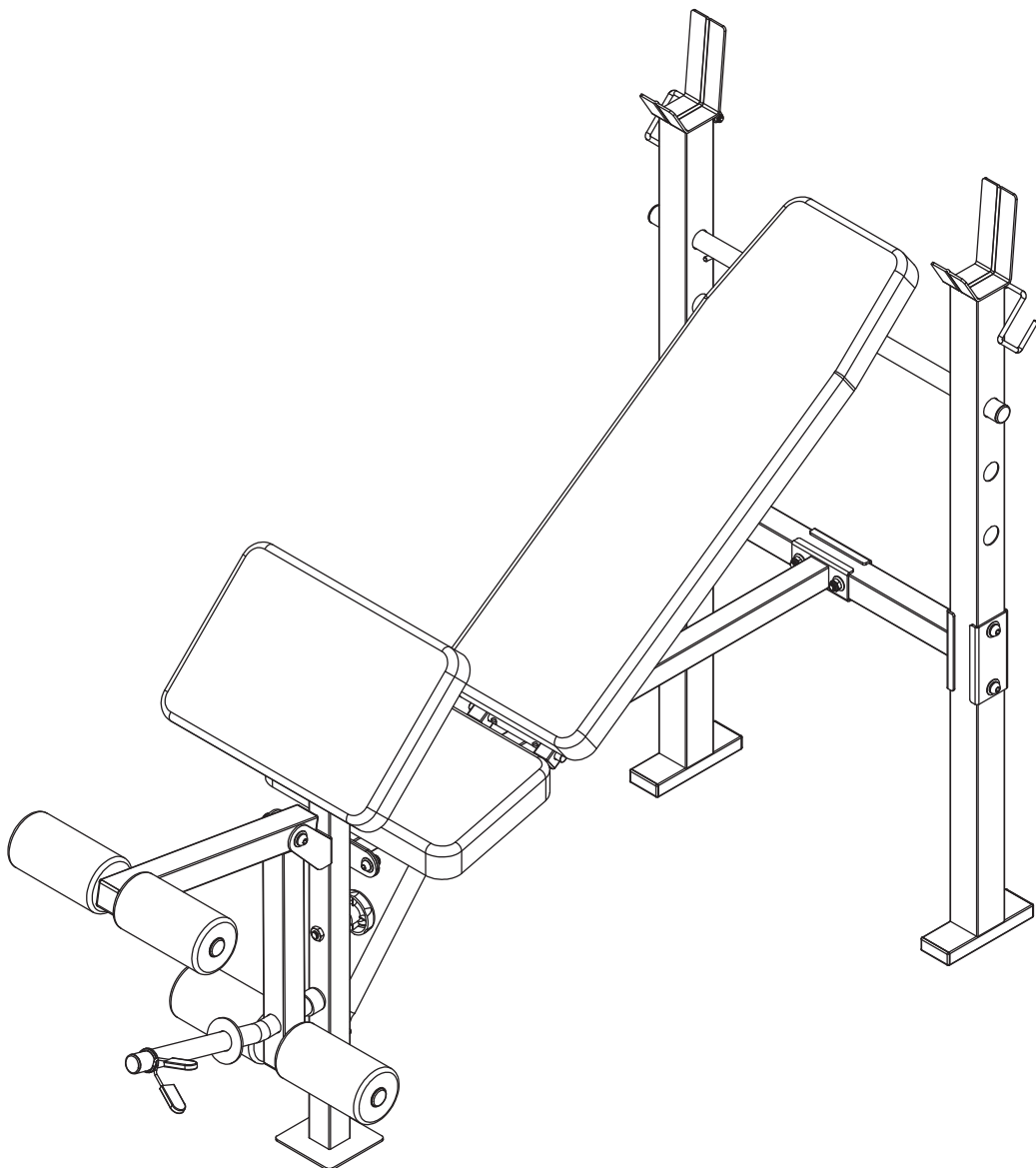

ESSENTIAL WORKOUT BENCH ADBE - 10452

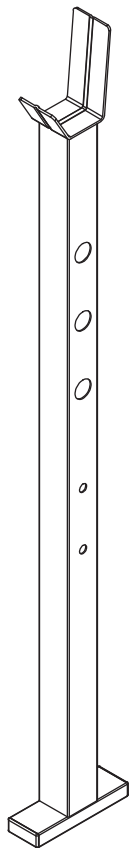



No.1x2

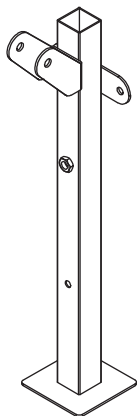

No.2x1

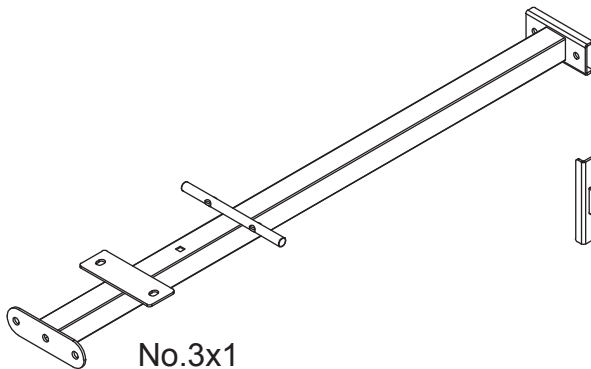

No.3x1

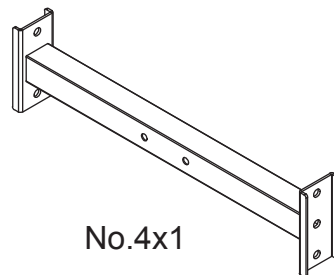

No.4x1

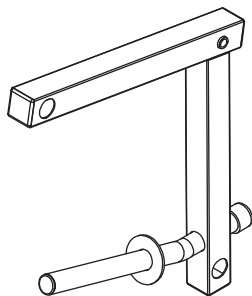

No.5x1

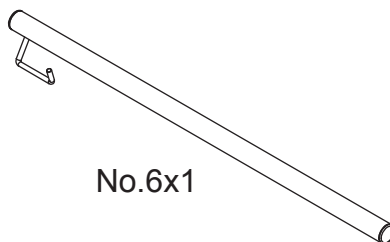

No.6x1

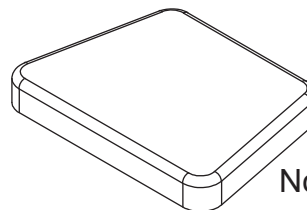

No.10x1

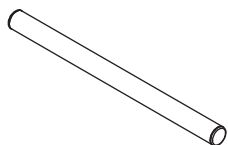

No.9x2

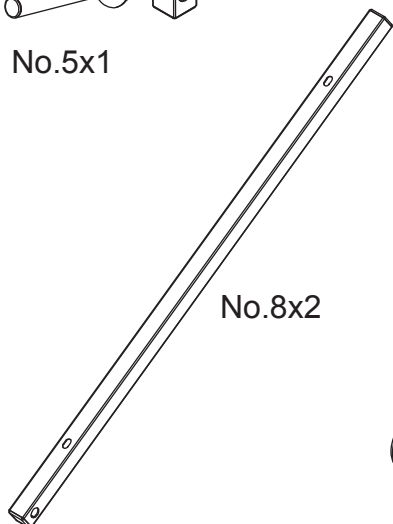

No.8x2



No.7x1

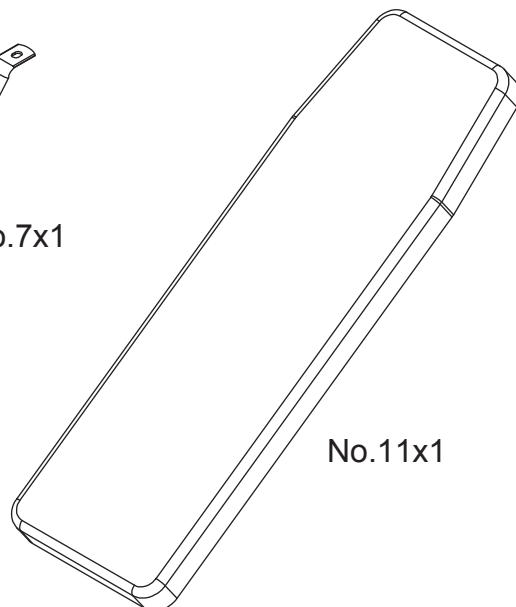

No.11x1



No.12x4

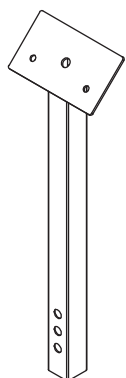

No.31x1



No.13x2



No.14x1



No.38x1

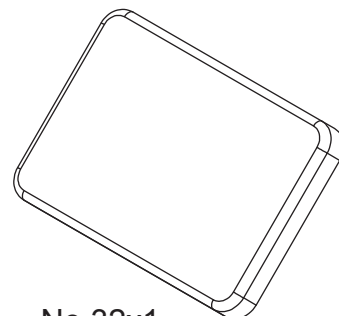

No.32x1



No.27x1



No.33x1



No.39x1

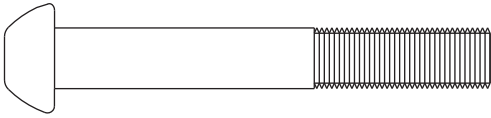

15 M10 x 70mm Bolt Qty: 1

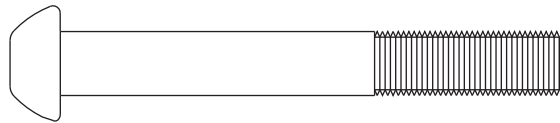

16 M10 x 75mm Bolt Qty: 4

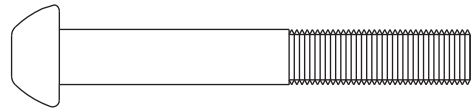

17 M8 x 60mm Bolt Qty: 2

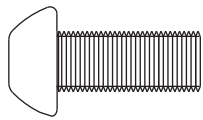

18 M8 x 20mm Bolt Qty: 2

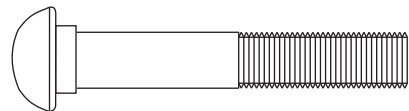

19 M8 x 50mm Carriage Bolt Qty: 1

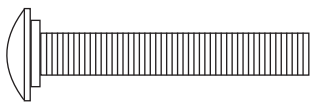

20 M6 x 40mm Bolt Qty: 4

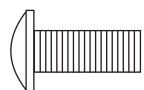

21 M6 x 15mm Bolt Qty: 4

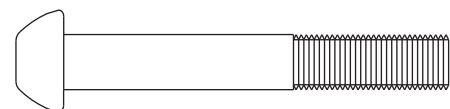

41 M8 x 55mm Bolt Qty: 1

Allen Wrench

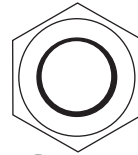
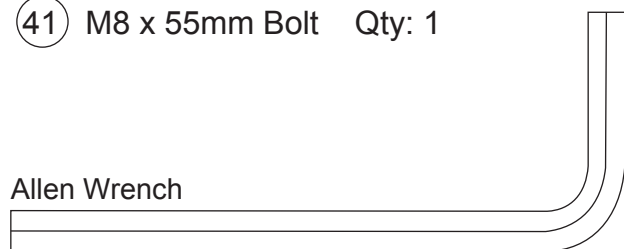

22 M10 Nylon Locknut Qty: 5



23 M8 Nylon Locknut Qty: 6

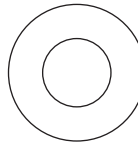

24 M10 Washer Qty: 10

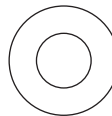

25 M8 Washer Qty: 11



34 M6 Washer Qty: 10

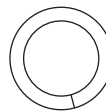







35 M10 Spring washer Qty: 5



36 M8 Spring washer Qty: 6



40 M6 Nylon Nut Qty: 2

- | | | |
|----|---|-----------------|
| ①⑥ |  | × 4 M10 x 75 mm |
| ②② |  | × 4 M10 |
| ②④ |  | × 8 M10 |
| ③④ |  | × 2 M6 |
| ③⑤ |  | × 4 M10 |
| ④① |  | × 2 M6 |

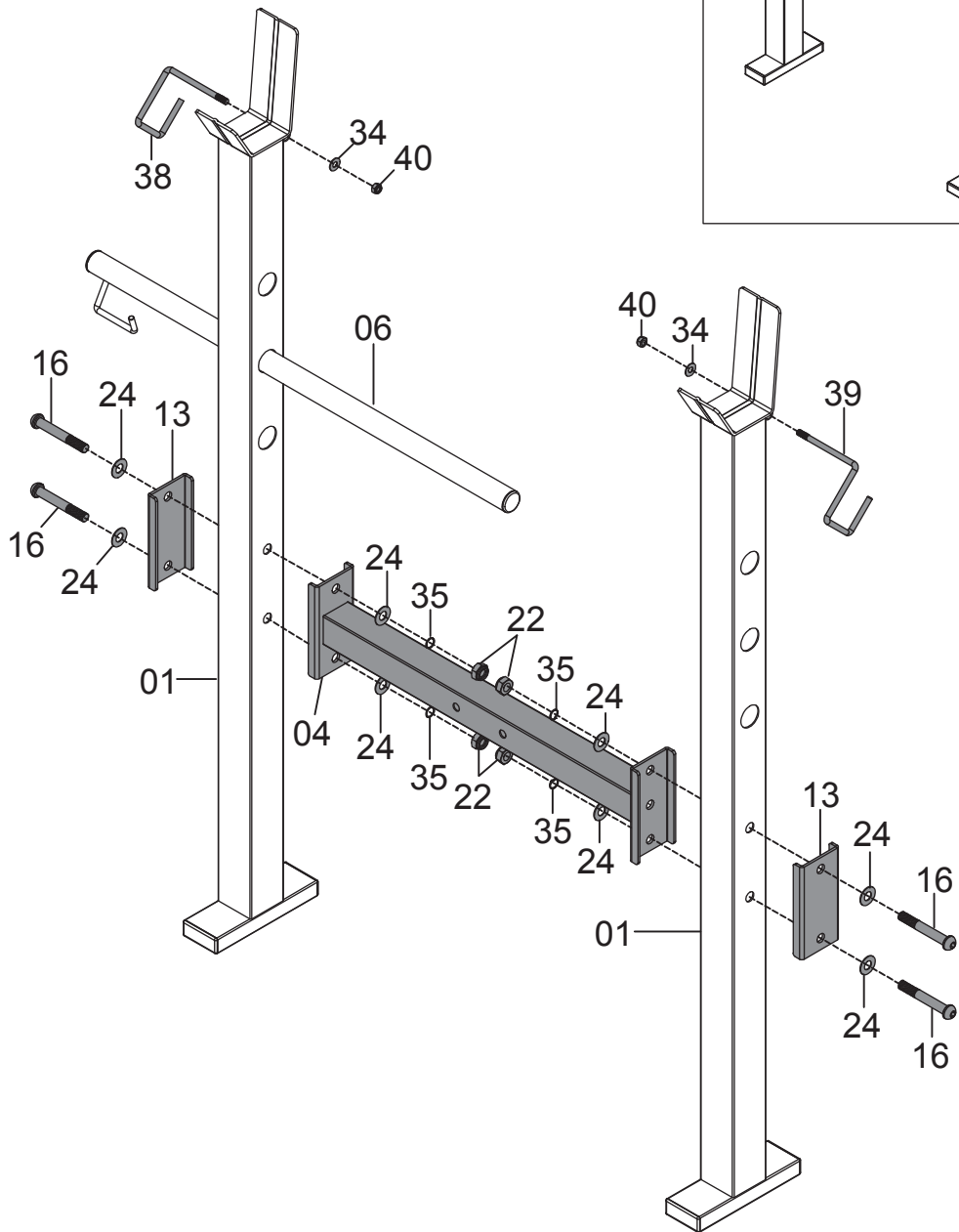
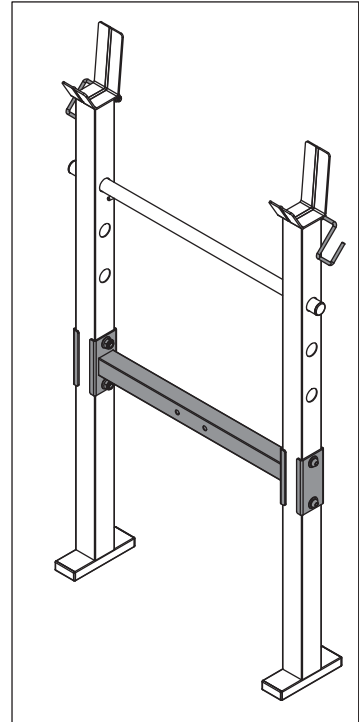
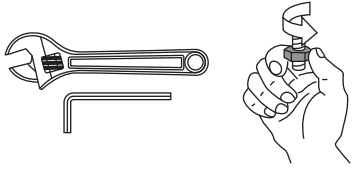

- | | | |
|----|---|----------------|
| ⑰ |  | × 2 M8 x60 mm |
| ⑱ |  | × 2 M8 x 20 mm |
| ⑲ |  | × 1 M8 x 50 mm |
| ④① |  | × 1 M8 x55 mm |
| ⑳ |  | × 6 M8 |
| ㉕ |  | × 11 M8 |
| ㉖ |  | × 6 M8 |

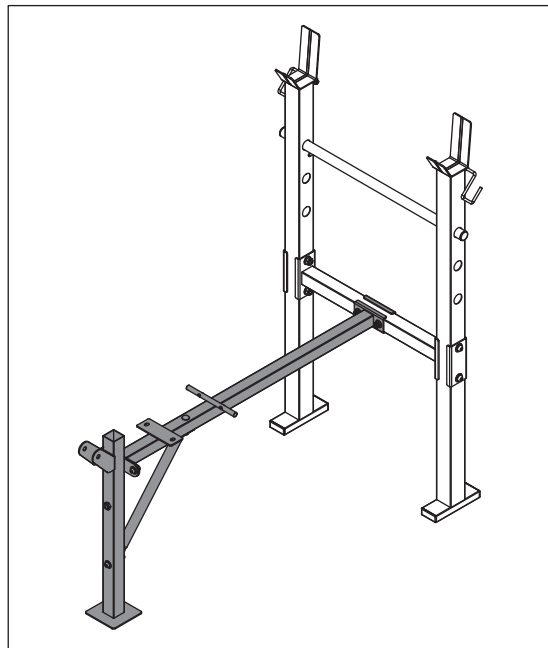
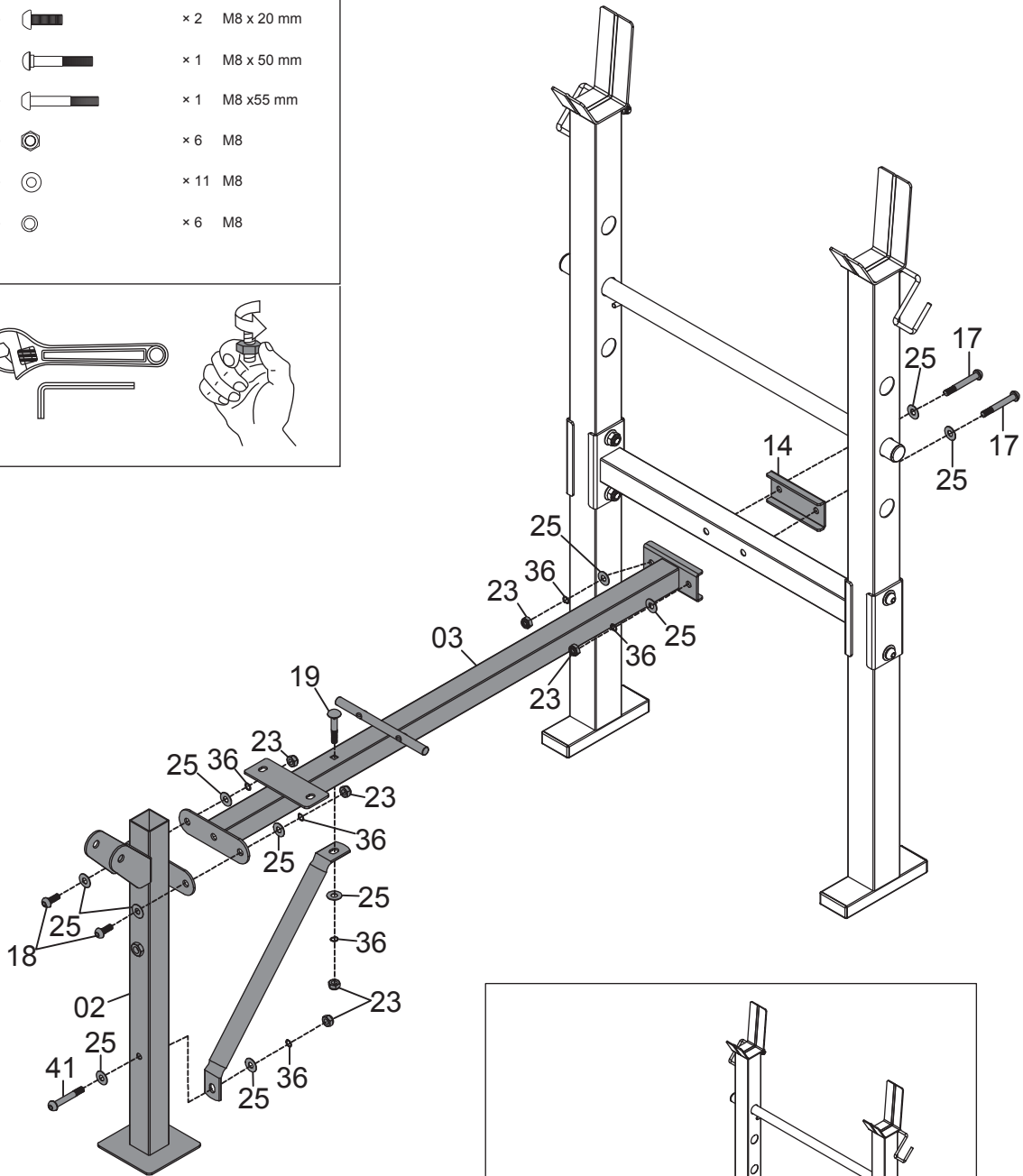
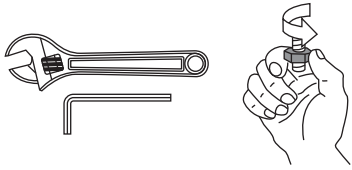

- | | | |
|---|---|-----------------|
| ⑮ |  | × 1 M10 x 70 mm |
| ⑳ |  | × 1 M10 |
| ㉔ |  | × 2 M10 |
| ㉕ |  | × 1 M10 |

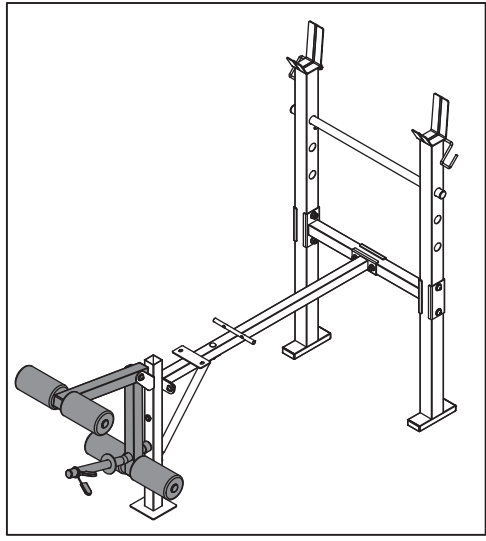
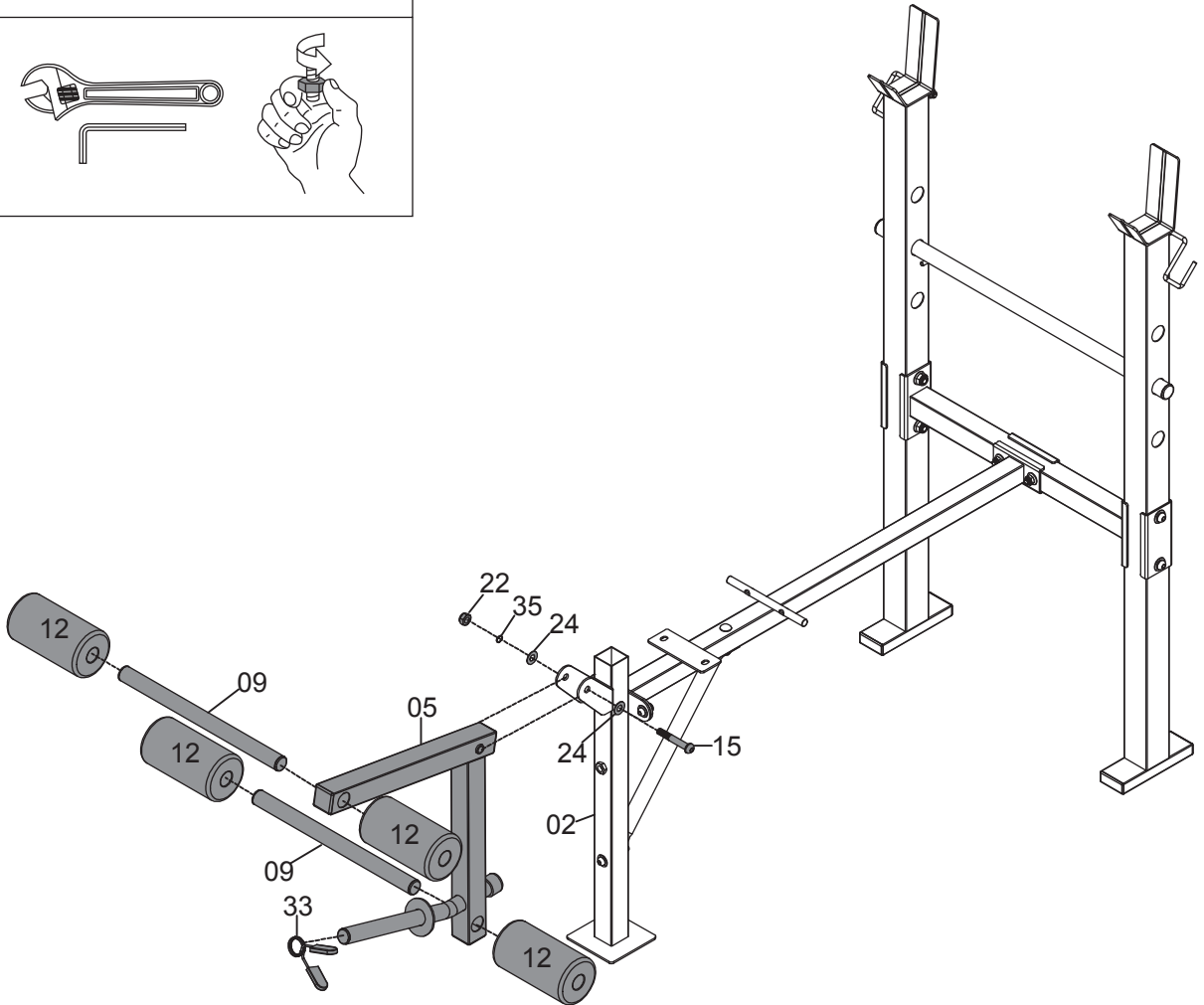
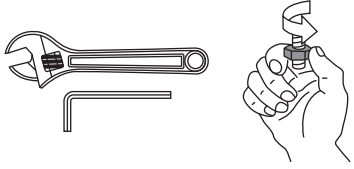

20  × 4 M6 x 40 mm

34  × 4 M6

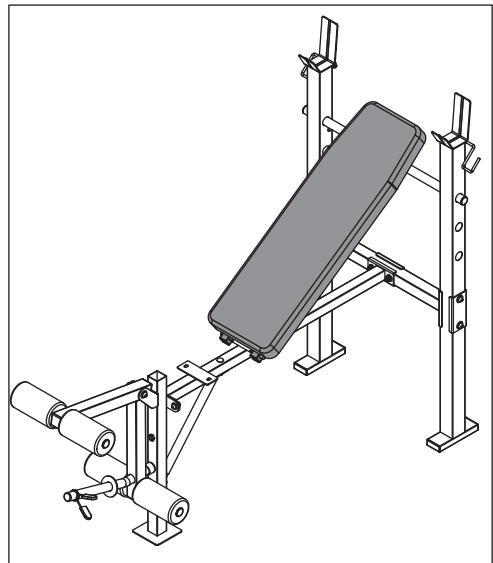
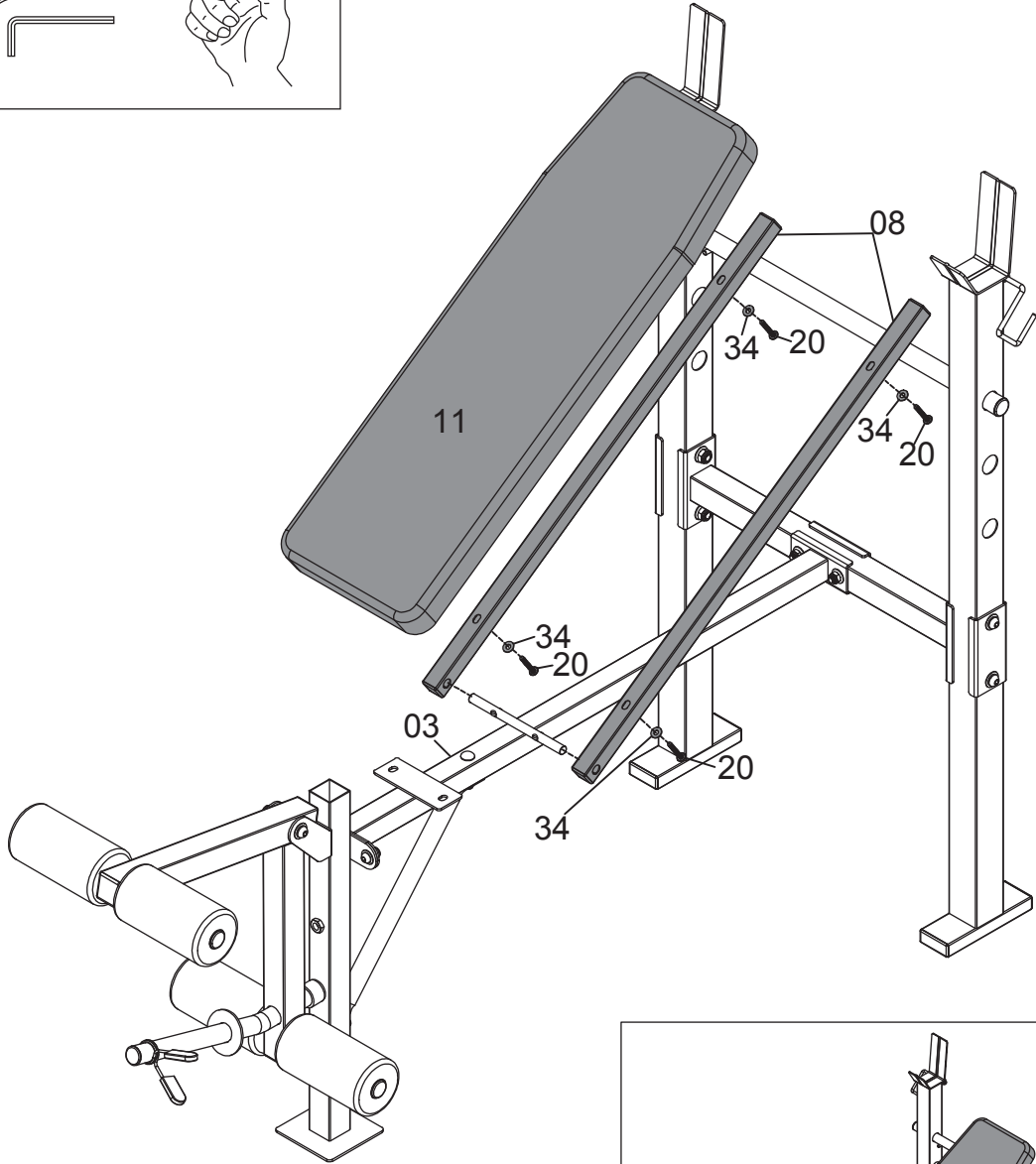
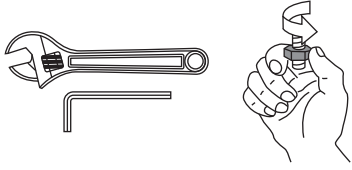

21



× 2 M6 x 15 mm

34



× 2 M6

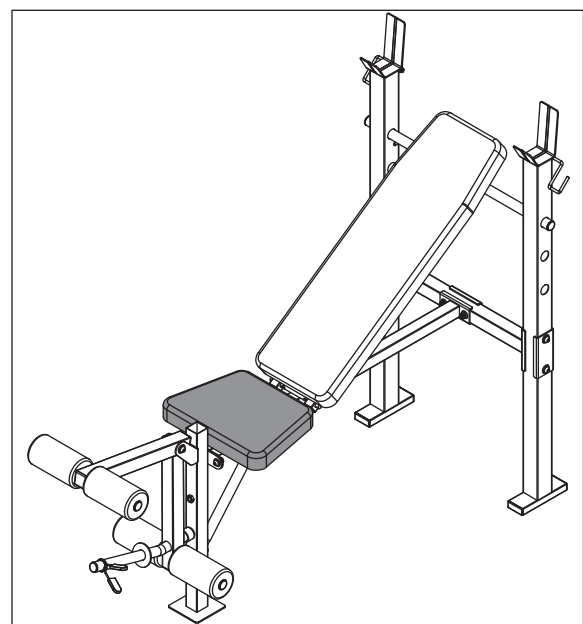
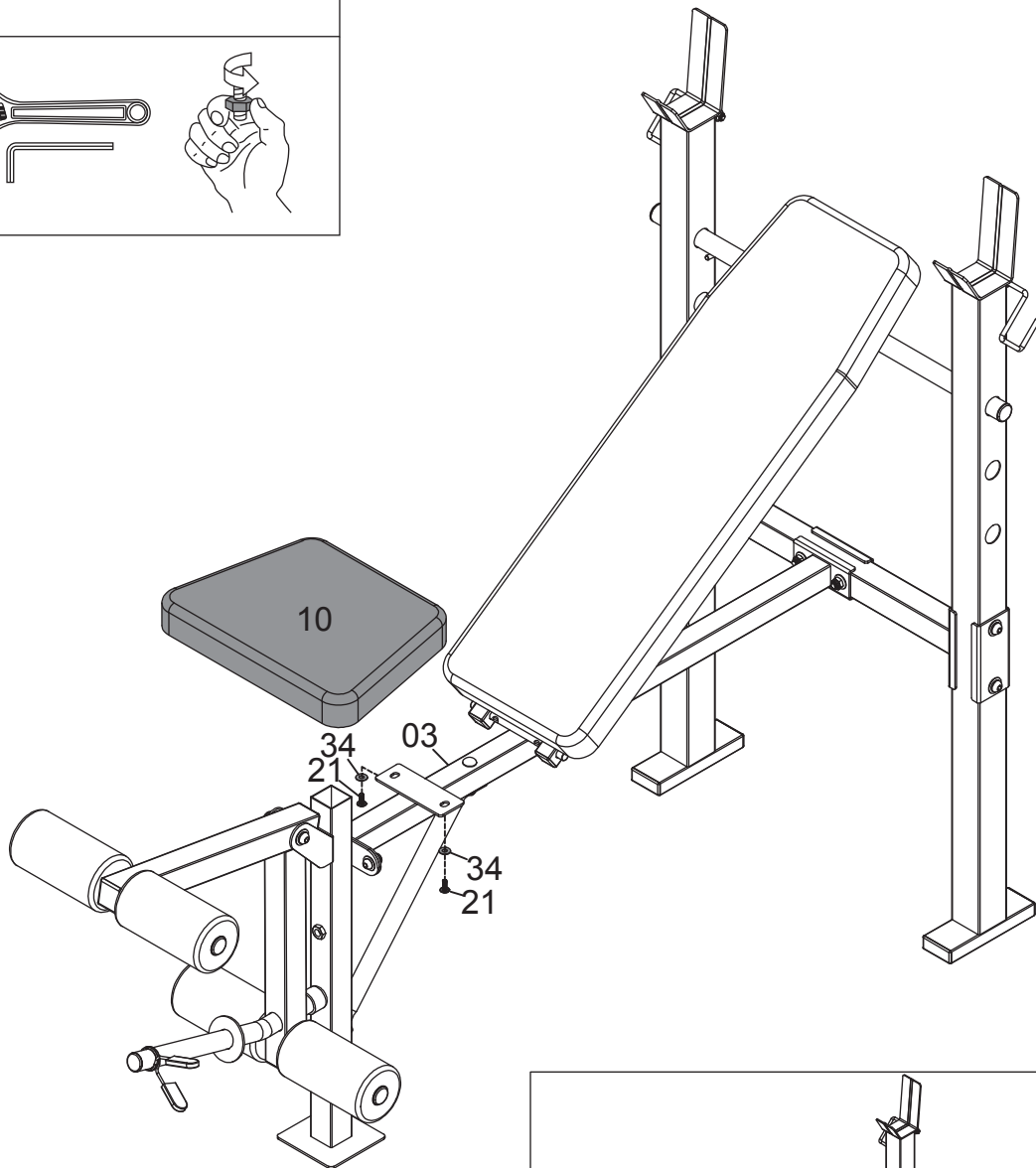
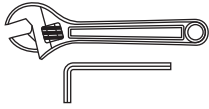

21



× 2 M6 x 15 mm

34



× 2 M6

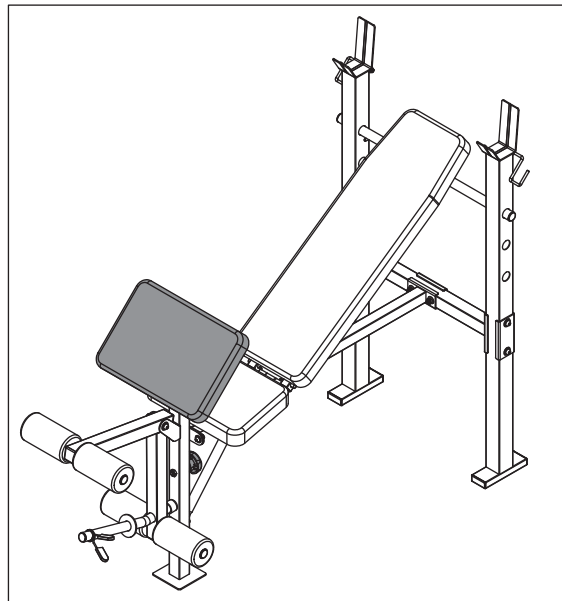
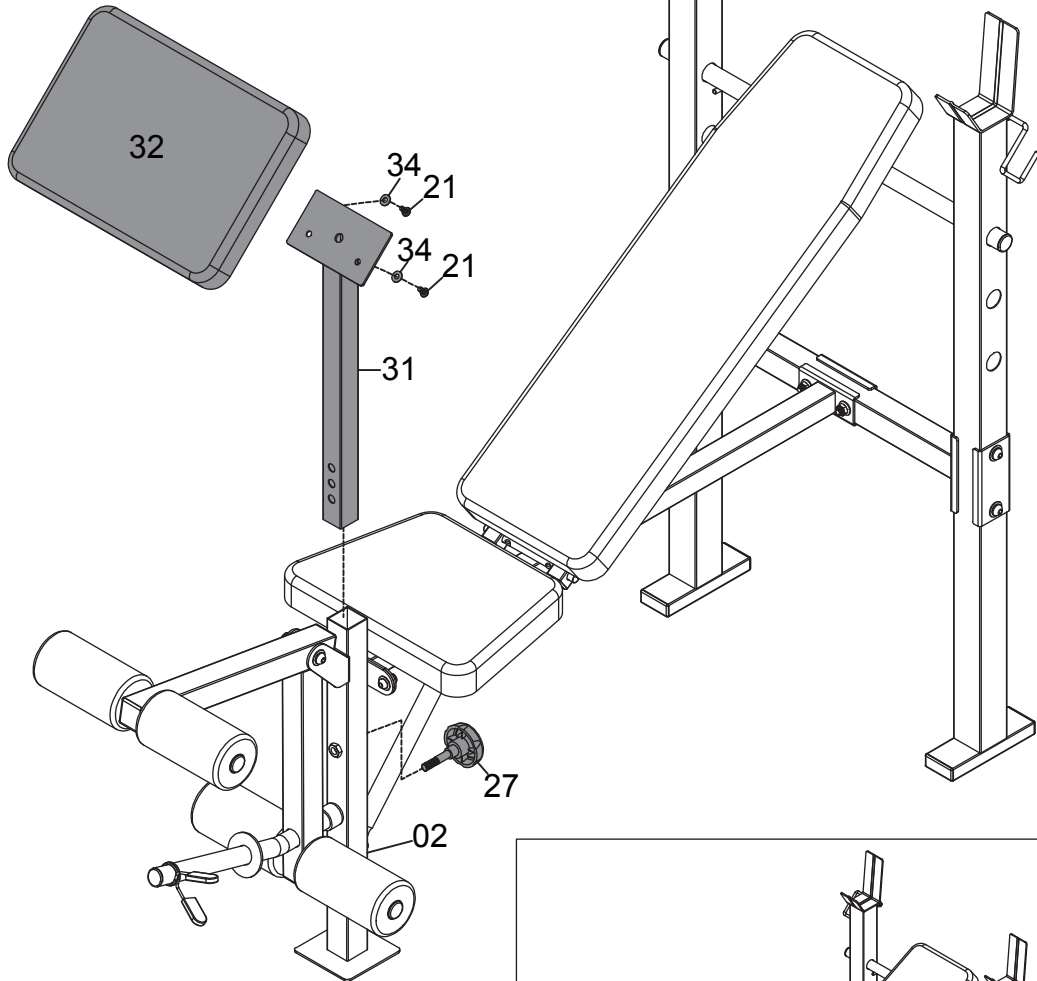
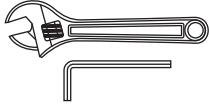

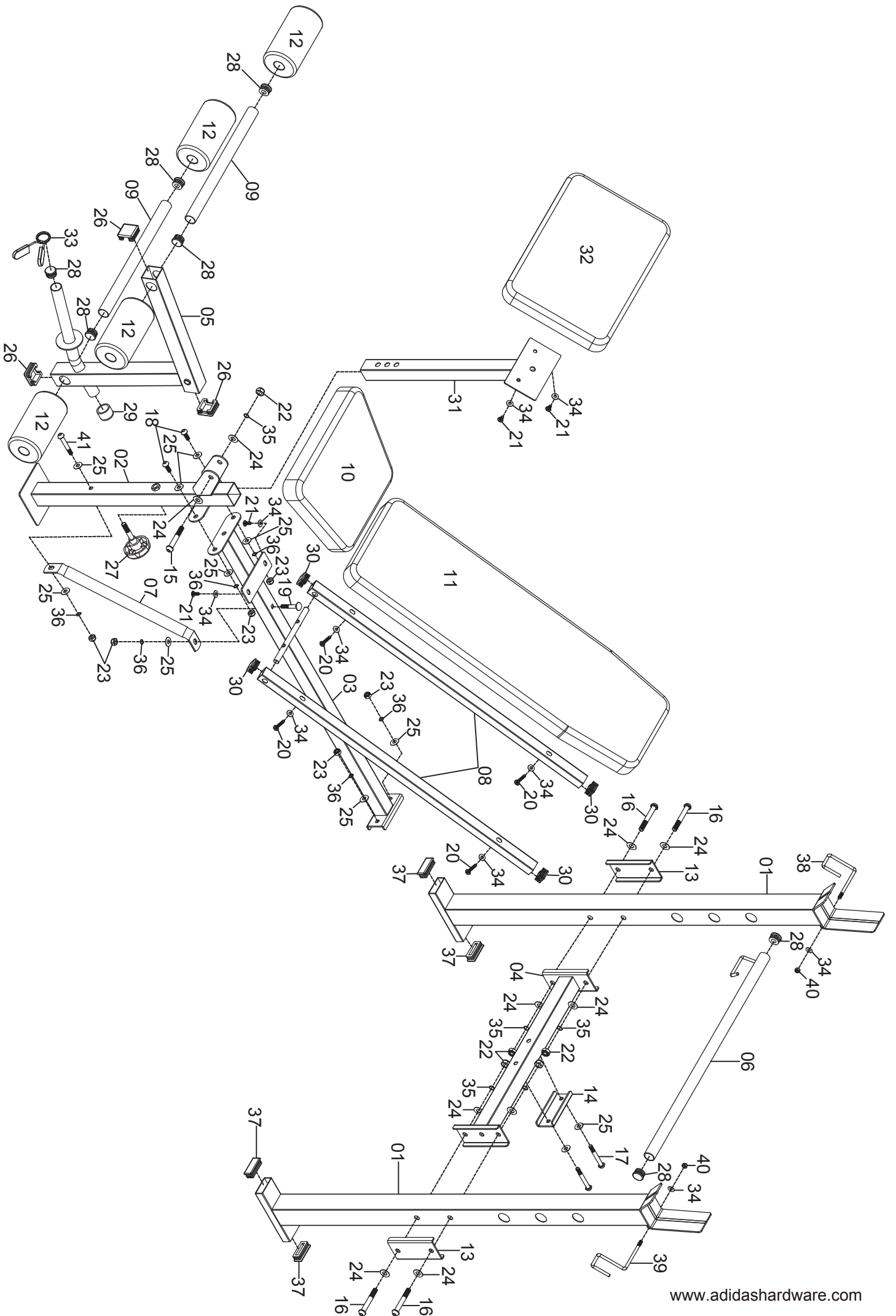

No.	Part No.	Description	Qty.
1	PFMCS7230-01	Upright	2
2	PFMAD7230AN-01	Front Leg	1
3	PFMCS7230-03	Frame	1
4	PFMCS7230-04	Cross bar	1
5	PFMAD7230AN-02	Leg Tube	1
6	PFMCS7230-06	Backrest Adjustment Tube	1
7	PFM7230-08	Support Bar	1
8	PFMCS7230-07	Backrest Tube	2
9	PFMCS7101-11	Foam Roller Tube	2
10	PFMCS7230-08	Seat	1
11	PFMCS7230-09	Backrest	1
12	PFMCS701-05	Foam Roller	4
13	PFMH1007A-23	Support Plate for Upright	2
14	PFMCS7230-10	Support Plate for Cross Bar	1
15	PFM2240-22	M10 x 70mm Bolt	1
16	PFM2240-21	M10 x 75mm Bolt	4
17	PFMS80-17	M8 x 60mm Bolt	2
18	PFM504-22	M8 x 20mm Bolt	2
19	PFMSCS80B-17	M8 x 50mm Carriage Bolt	1
20	PFM2240-24	M6 x 40mm Bolt	4
21	PFM2240-23	M6 x 15mm Bolt	4
22	PRK1-05	M10 Nylon Locknut	5
23	PHHKRK6-10	M8 Nylon Locknut	6
24	PRK1-06	M10 Washer	10
25	PFM2006-27	M8 Washer	11
26	PRK3B-05	38mm Square Inner Cap	3
27	PFM6240E-20	M10x45mm Knob	1
28	PRK1-03	25mm Round Inner Cap	7

No.	Part No.	Description	Qty.
29	PFM2240-19	25mm Round Angled Cap	1
30	PFM2240-32	25mm Square Inner Cap	4
31	PFMAD7230AN-03	Arm Curl Tube	1
32	PFMAD7230AN-04	Arm Curl Pad	1
33	FM-AD7240RD-38	Sprig Clip	1
34	PFMS80-22	M6 Washer	10
35	FMAD613-06	M10 Spring washer	5
36	FMAD613-07	M8 spring washer	6
37	PFMAD7230AN-05	20x50mm Square Inner Cap	4
38	PFMAD7230AN-06	Right Safety Hook	1
39	PFMAD7230AN-07	Left Safety Hook	1
40	FM-AD7240RD-28	M6 Nylon Nut	2
41	PFMAD7230AN-08	M8 x 55mm Bolt	1
42		Allen Wrench	1

For product information or service please contact:

UK:

RFE Europa Ltd. 8 Clarendon Drive, Wymbush, Milton Keynes, MK8 8ED.
Customer Service: Tel: +44 (0)800 440 2459
Email: techsupport@rfeinternational.com

Europe:

Email: serviceeuropa@rfeinternational.com

Spain:

Email: serviciotecnico@rfeinternational.com

APAC (excluding Australia):

RFE Asia Pacific, 2608-1609, 1 Hung To Road, Kwun Tong, Kowloon, Hong Kong.
Customer Service: Tel: +852 34685027
Email: techsupportapac@rfeinternational.com

Australia:

Email: techsupportaustralia@rfeinternational.com

USA:

RFE Sporting Goods Inc., 1300 Smith Road, STE 104, Austin, Texas, 78721, USA.
Customer Service: Tel: +1 (800) 215 6216
Email: techsupportusa@rfeinternational.com

La **garantía ARGENTRADE SRL** cubre todo defecto o falla que pudiera producirse en el producto como consecuencia de partes estructurales que demuestren haber resultado defectuosas **durante los primeros 6 (seis) meses a partir de la fecha de compra.**

Quedan excluidos de la garantía daños provocados por accidentes, golpes o uso indebido del producto (abuso de la función o de la resistencia técnica indicada).

Se asegura la reparación del mismo en un plazo que no puede exceder los **60 (sesenta) días a partir de la fecha** de la solicitud de la reparación, ampliable por razones de fuerza mayor.

BENEFICIOS

- Nuestros centros de servicio autorizado le validarán la garantía de 6 (seis) meses al presentar el recibo que prueba su compra en un vendedor autorizado.
- Por favor, guarde ese recibo como prueba de su compra. Deberá presentarlo para obtener el servicio incluido en nuestra garantía de **6 (seis) meses.**

LA GARANTÍA DE 6 (seis) meses NO INCLUYE

- Deterioro resultado del desgaste normal, accidental o por negligencia. Por favor, lea el manual de instrucciones para el mantenimiento de su equipo.
- Equipos comprados a vendedores no autorizados por **ARGENTRADE.**
- Reparaciones realizadas por un tercero no autorizado.

Si necesita realizar cualquier tipo de reparación, por favor, póngase en contacto con un agente del servicio técnico autorizado a través de **Tel: 0810-345-0447** o por mail a sat@argentrade.net / postventa@argentrade.net

Para hacer efectiva dicha garantía es absolutamente imprescindible exhibir la factura de compra del producto.

ARGENTRADE se reserva el derecho de determinar si está en conformidad con los términos y las condiciones de la garantía de 6 meses. La misma se aplica y tiene validez solamente en el país de compra.

En caso de necesitar repuestos o asesoramiento, dirigirse a:

Calle 514 Nº 2050 (1901) Ringuelet - La Plata - Bs.As. Tel: 0810-345-0447

Información del producto o su uso: sat@argentrade.net / postventa@argentrade.net

